

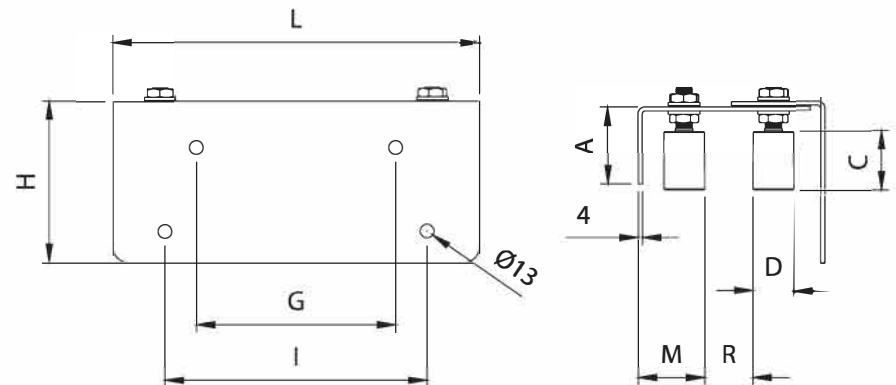

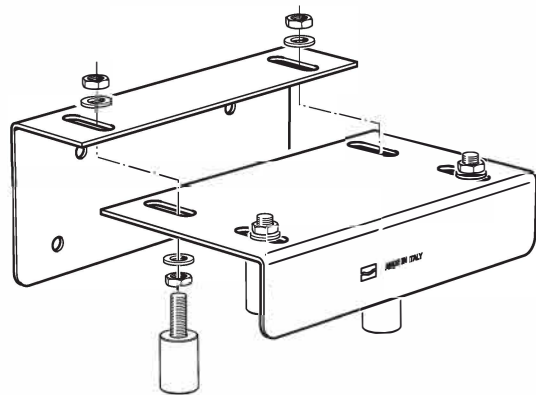

# Art. CG-251



TECHNICAL CHARACTERISTICS				
		CG-251	CGI-251	
WEIGHT OF PART		6,70 Kg	6,70 Kg	
GATE MIN. THICKNESS		70 mm	70 mm	
GATE MAX. THICKNESS		110 mm	110 mm	
MAINTENANCE FREQUENCY				
PRIVATE HOME	COMPANY	WAREHOUSE	CONDOMINIUM <20 UNITS	CONDOMINIUM > 20 UNITS
2 YEARS*	2 YEARS*	2 YEARS*	1 YEAR*	1 YEAR*
Check rollers.				
Check fixing.				
*The scheme refers to a normal workplace (not marine or particularly aggressive environments).				

Art.	Code	A	C	D	G	H	I	L	M	R		
CG-251	11310005 001	74	58	Ø40	190	154	230	350	44-88	70-110	1	6,70

Art.	INOX	A	C	D	G	H	I	L	M	R		
CGI-251	11310305	74	58	Ø40	190	154	230	350	44-88	70-110	1	6,70

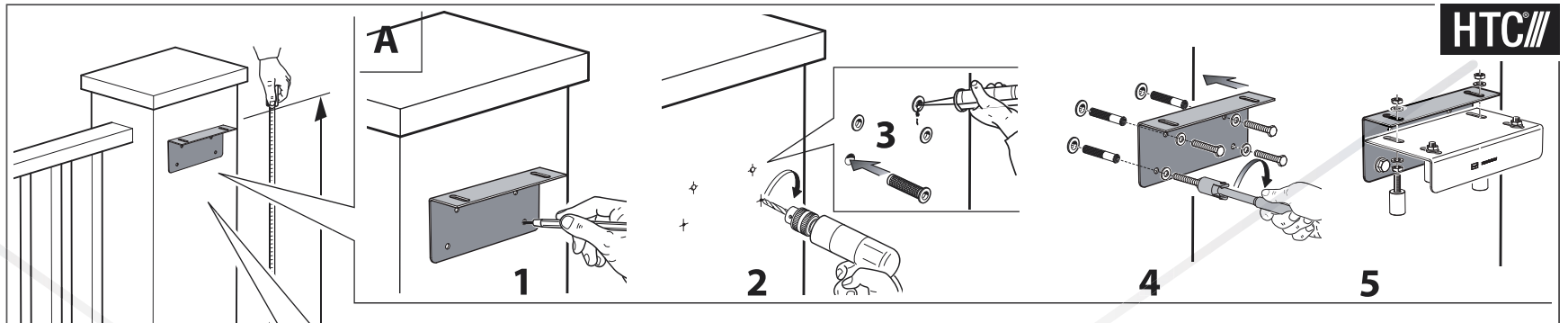
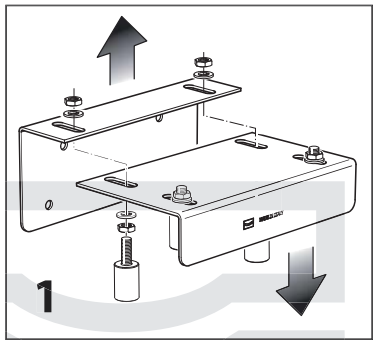
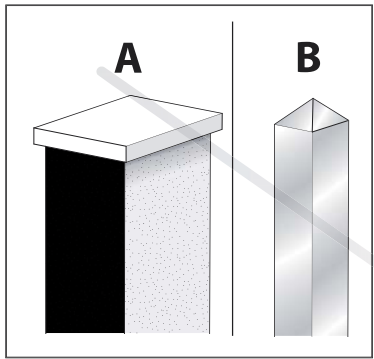

HTC

