

SWINGER

swing gates up to 2.5 m - 250 kg



NETLINK OPERATOR

This operator is compatible with the NETLINK System and can be programmed with DEAINstaller and NETBOX

Sliding arm

For gates with limited space (optional).



Supplied with Ziggy remotes. Available with optional wall mount.



Integrated mechanical stops for open and closed positions



RUBBER RISER

For gates using rising hinges (optional).





Compatible with the Apps



KIT

DIMENSIONS WITH STANDARD ARM

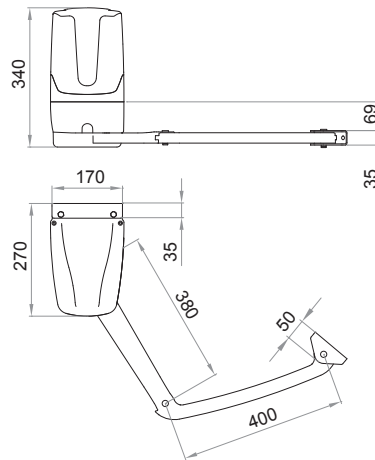

Articulated arm

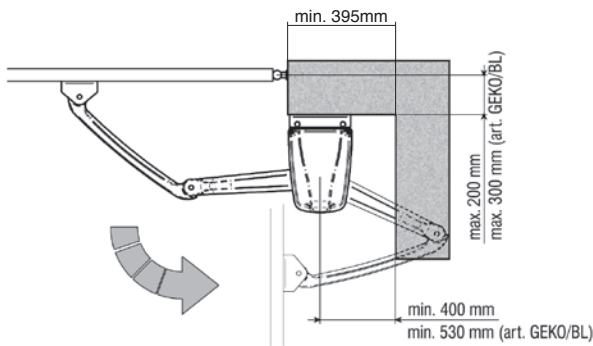

Sliding arm

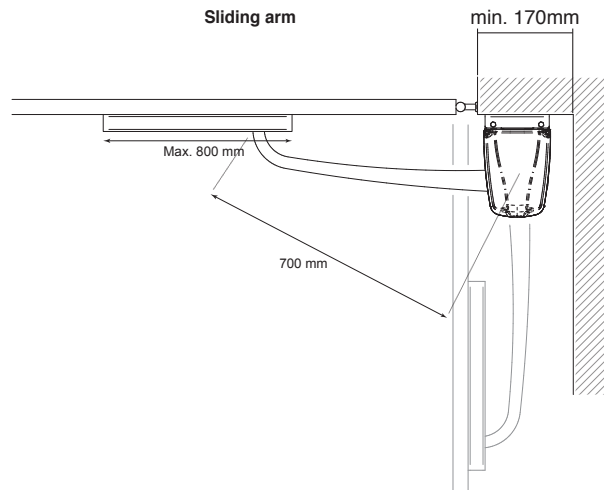

Refer to instructions manual for installation dimensions

ARM OPTIONS

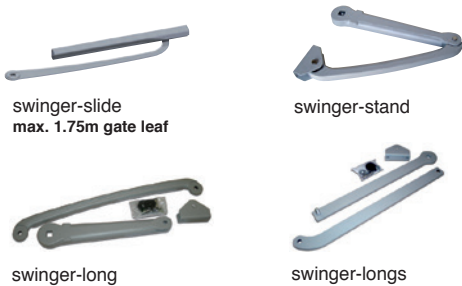

USAGE GUIDE

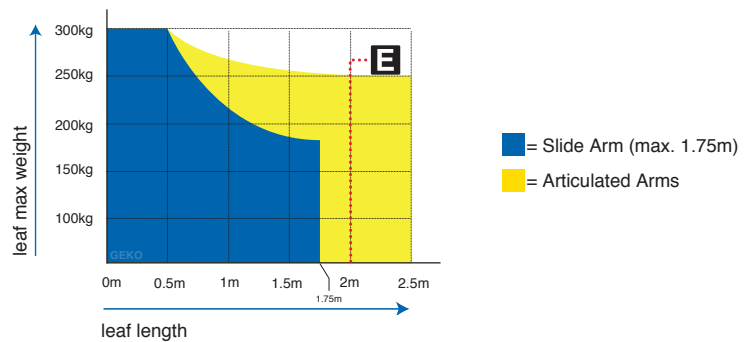

E If the leaf length is longer than 2m it's important to install an electric-lock to secure the gate in closed position. Otherwise damage to the motor may occur if the gate is forced open.

Tall gates with solid infill are subjected to excessive wind forces. As such it may necessary to use an electric lock on gates less than 2m.

TECHNICAL INFO	
Motor power supply (V)	24V ~
Maximum power absorption (W)	80
Max torque (Nm)	180
Duty cycle (cycles/hours)	20
N. max cycles in 24h.	60
Operating temperature (°C)	-20 ÷ 50
90° Opening time (s)	16
Weight with packing (Kg)	12
Sound pressure (dBA)	< 70
Protection level	IP44

Swinger Arm Dimensions

All arm measurements are centre-to-centre

SWINGER-STAND
Standard Swinger arm

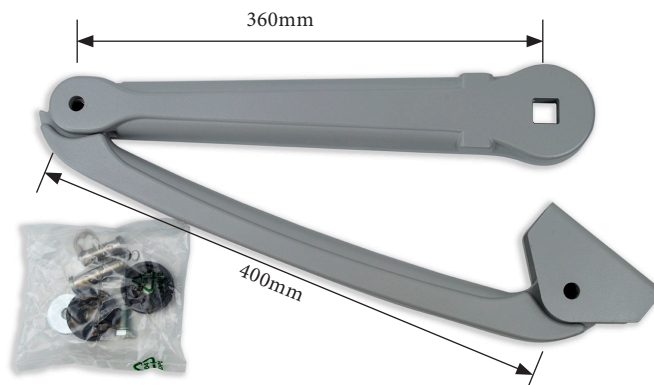

SWINGER-LONG
Long-reach aluminium arm

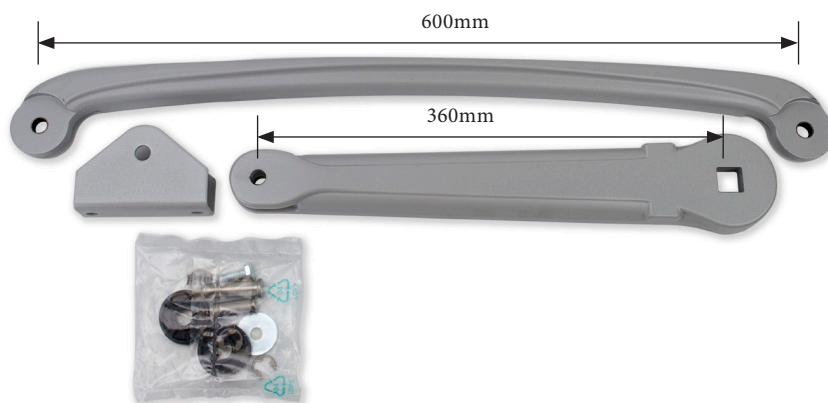

SWINGER-LONGS
Long-reach steel arm.

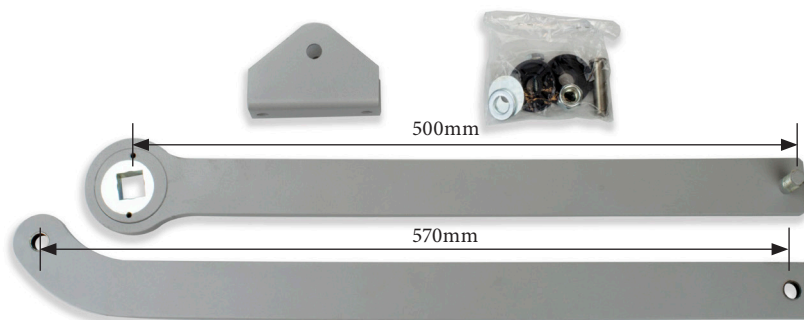

SWINGER-SLIDE
Slide arm for tight spaces.

